

20V N-Channel Enhancement Mode MOSFET

VDS= 20V

RDS(ON), Vgs@ 4.5V, Ids@ 4.5A < 25mΩ

RDS(ON), Vgs@ 2.5V, Ids@ 3.1A < 45mΩ

Features

Advanced trench process technology

High Density Cell Design For Ultra Low On-Resistance

High Power and Current handing capability

Ideal for Li ion battery pack applications

Package Dimensions

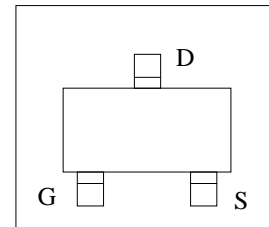
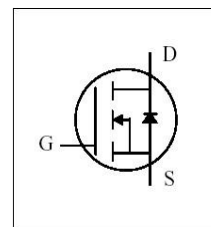
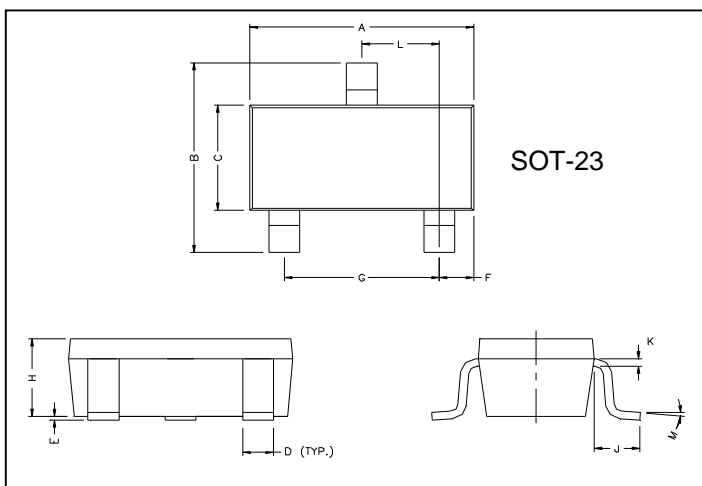

REF.	Millimeter		REF.	Millimete	
	Min.	Max.		Min.	Max.
A	2.80	3.00	G	1.80	2.00
B	2.30	2.50	H	0.90	1.1
C	1.20	1.40	K	0.10	0.20
D	0.30	0.50	J	0.35	0.70
E	0	0.10	L	0.92	0.98
F	0.45	0.55	M	0°	10°

Maximum Ratings and Thermal Characteristics (TA = 25°C unless otherwise noted)

Parameter	Symbol	Limit	Unit	
Drain-Source Voltage	V _{DS}	20	V	
Gate-Source Voltage	V _{GS}	± 10		
Continuous Drain Current	I _D	4.6	A	
Pulsed Drain Current ¹⁾	I _{DM}	8		
Maximum Power Dissipation	P _D	TA = 25°C	1.25	W
		TA = 75°C	0.8	
Operating Junction and Storage Temperature Range	T _J , T _{stg}	-55 to 150	°C	
Junction-to-Ambient Thermal Resistance (PCB mounted) ²⁾	R _{θJA}	78	°C/W	

Notes

¹⁾ Pulse width limited by maximum junction temperature.

²⁾ Surface Mounted on FR4 Board, t ≤ 5 sec.

ELECTRICAL CHARACTERISTICS (TA = 25°C unless otherwise noted)

Parameter	Symbol	Test Condition	Min.	Typ.	Max.	Unit
Static³⁾						
Drain-Source Breakdown Voltage	BV_{DSS}	$V_{GS} = 0V, I_D = 250\mu A$	20			V
Drain-Source On-State Resistance	$R_{DS(on)}$	$V_{GS} = 2.5V, I_D = 3.1A$		22.0	35.0	mΩ
Drain-Source On-State Resistance	$R_{DS(on)}$	$V_{GS} = 4.5V, I_D = 3.6A$		20.0	25.0	
Gate Threshold Voltage	$V_{GS(th)}$	$V_{DS} = V_{GS}, I_D = 250\mu A$	0.6	0.76		V
Zero Gate Voltage Drain Current 0	I_{DSS}	$V_{DS} = 20V, V_{GS} = 0V$			1	μA
Gate Body Leakage	I_{GSS}	$V_{GS} = \pm 12V, V_{DS} = 0V$			±100	nA
Forward Transconductance	g_{fs}	$V_{DS} = 5V, I_D = 4.2A$		5	—	S
Dynamic⁴⁾						
Total Gate Charge	Q_g	$V_{DS} = 10V, I_D = 3.6A$ $V_{GS} = 4.5V$		5.4	10	nC
Gate-Source Charge	Q_{gs}			0.65		
Gate-Drain Charge	Q_{gd}			1.5		
Turn-On Delay Time	$t_{d(on)}$	$V_{DD} = 10V, R_G = 6\Omega$ $I_D = 1A, V_{GS} = 4.5V$ $R_L = 5.5\Omega$		12	25	ns
Turn-On Rise Time	t_r			36	60	
Turn-Off Delay Time	$t_{d(off)}$			34	60	
Turn-Off Fall Time	t_f			10	25	
Input Capacitance	C_{iss}	$V_{DS} = 10V, V_{GS} = 0V$ $f = 1.0\text{ MHz}$		340		pF
Output Capacitance	C_{oss}			115		
Reverse Transfer Capacitance	C_{rss}			33		
Source-Drain Diode						
Max. Diode Forward Current	I_S				1.6	A
Diode Forward Voltage	V_{SD}	$I_S = 1.0A, V_{GS} = 0V$			1.0	V

Notes

- 3) Short duration test pulse used to minimize self-heating effect.
- 4) Pulse test pulse width ≤ 300μs, duty cycle ≤ 2%.

